

# Red Pin Steel Dock Board - Model C

*Bluff Steel Dock Boards provide an easy transition from dock to truck*

## Product Overview

**BLUFF**  
AN INTEGRATED WAREHOUSE SOLUTIONS BRAND

*Dock Equipment*

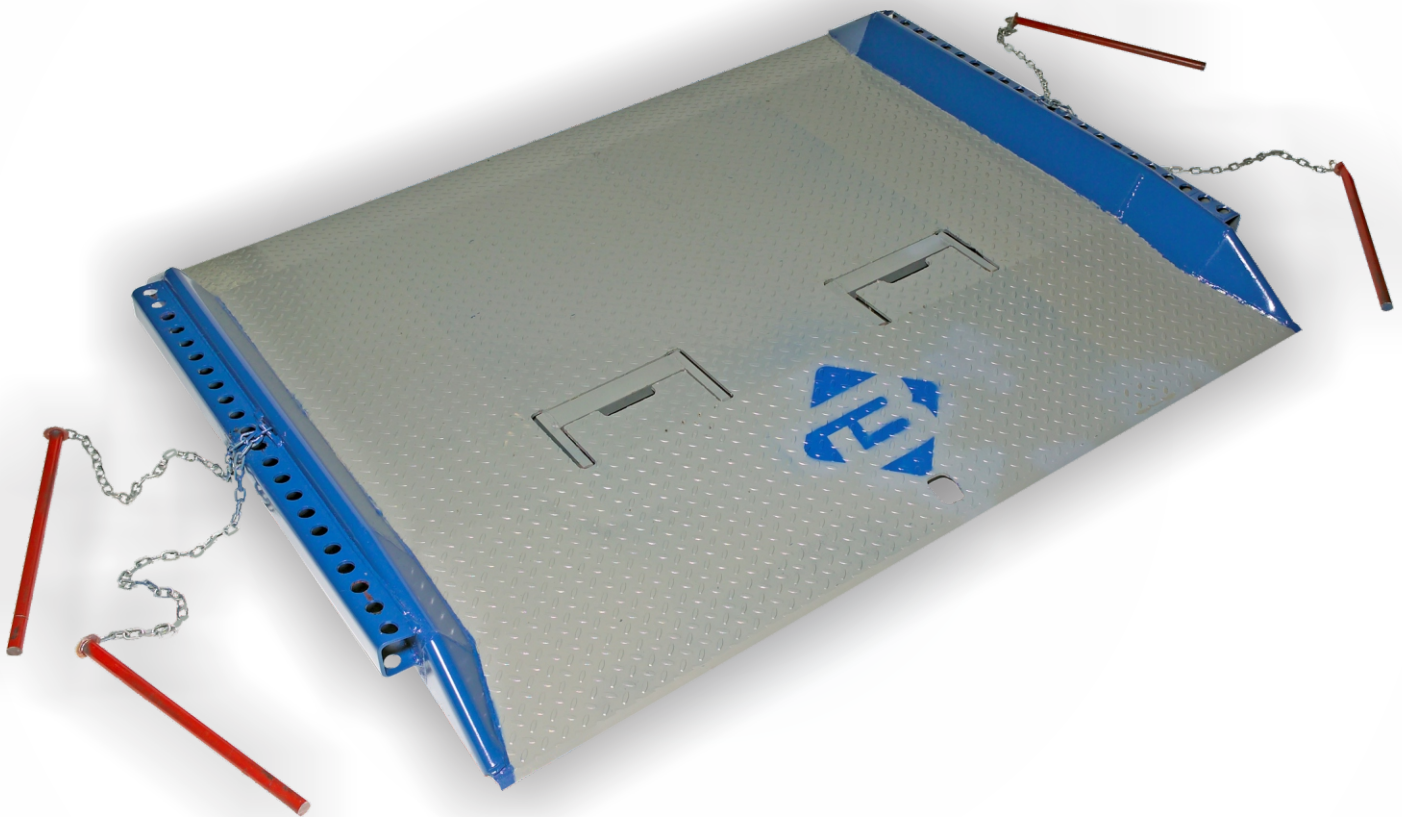

Manufactured and tested in compliance  
ANSI Standard MH30.2



Innovative Products  
Fast Lead Times

## Features

- For difficult dock to trailer positioning and park-out applications
- Full length pin pockets on each side for a dual-pin locking system
- Fold down lift loops
- All steel welded construction
- Capacities from 15,000 to 40,000 pounds
- Widths from 60" to 96"
- Lengths from 48" to 120"
- Above and below dock loading
- Great for temporary use over dock levelers that are being repaired

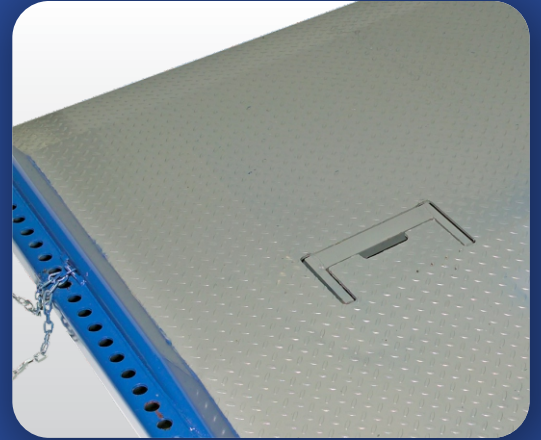

## Optional Features

- Speedy Board® option available
- Custom sizes and higher capacities available

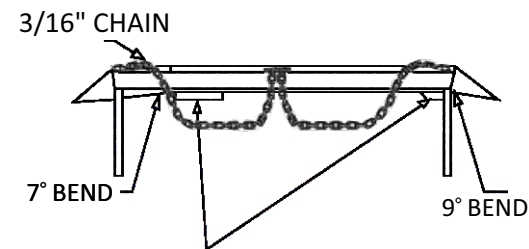
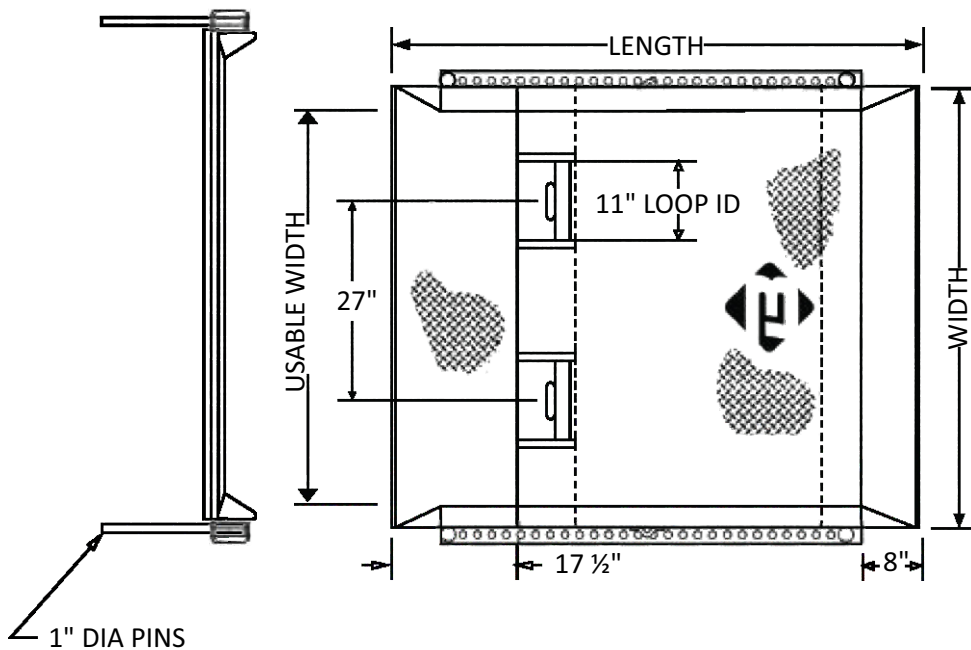

BOARD LENGTH	LEG LENGTH
48" — 60"	20"
66" — 72"	24"
78" — 84"	30"
90" — 96"	36"