

Aluminum Walk Ramps – Apron Style

Lightweight aluminum construction and apron style design for use with curbs or loading docks

Product Overview

BLUFF
MANUFACTURING

Yard Ramps



Manufactured and tested in compliance
ANSI Standard MH30.2



Innovative Products
Fast Lead Times

Features

- Nominal Lengths: 3' – 16'
- Actual Length: 36" – 189"
- Height Range: 9" – 61"
- Capacity Range: 500 – 3,000 lbs.
- 2900 Series Weight Range: 36 – 147 lbs.
- 3900 Series Weight Range: 43 – 176 lbs.
- Apron Size: 8"
- Position Stop Length: 3.25"
- Apron Size: 36"
- Brand: Magliner
- Twin-tooth deck for better traction when traveling in either direction
- Strong, lightweight aluminum construction makes ramps easily portable and convenient
- All apron models complete with 8" apron, 3¼" position stop, and safety chains

Note: Walk Ramps are not made for powered equipment or pallet jack use. Walk Ramps are intended for foot traffic use only.

Walk Ramp



Twin-tooth extruded deck

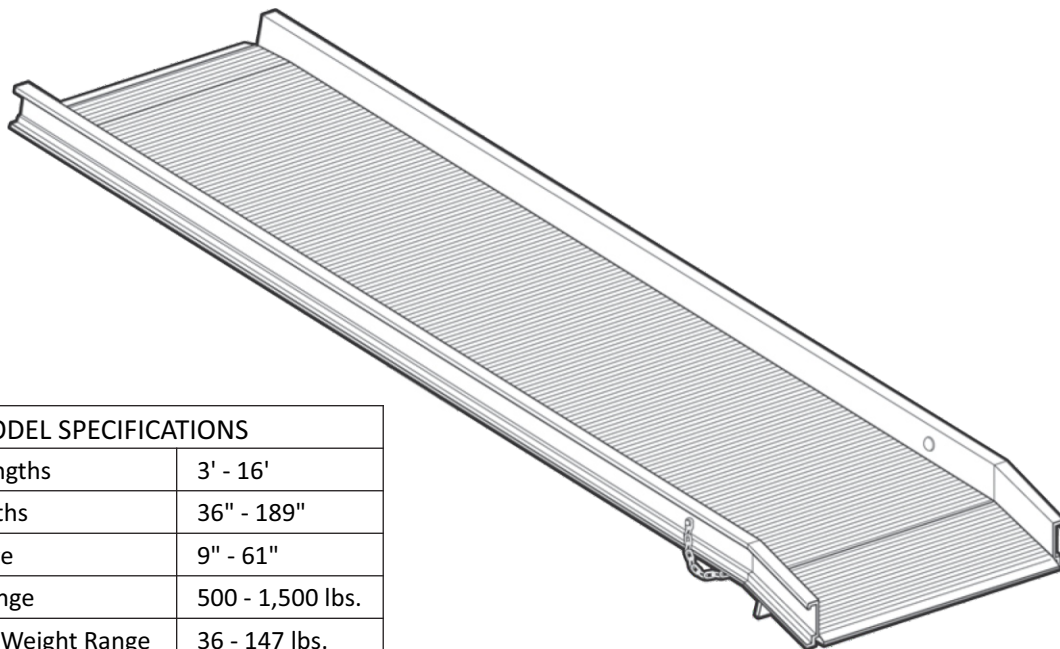
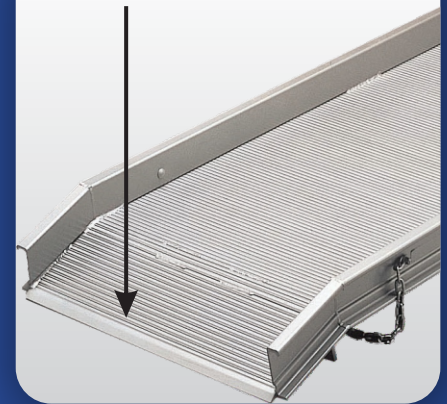

APRON MODEL SPECIFICATIONS

Nominal Lengths	3' - 16'
Actual Lengths	36" - 189"
Height Range	9" - 61"
Capacity Range	500 - 1,500 lbs.
2900 Series Weight Range	36 - 147 lbs.
3900 Series Weight Range	43 - 176 lbs.
Apron Size	8"